

TECHNICAL SPECIFICATION

PRODUCT CODE: DYN1-S-S (Single Monitor)
DYN1-D-S (Dual Monitor)

- Weight Capacity 15kg
- Height Adjustment 580mm height range
- Quick Release for easy screen removal
- 90° up and 40° downward tilt
- 150° left/right pan
- 461mm arm reach
- 75mm or 100mm VESA compatible
- Silver Finish
- 7 Year Warranty

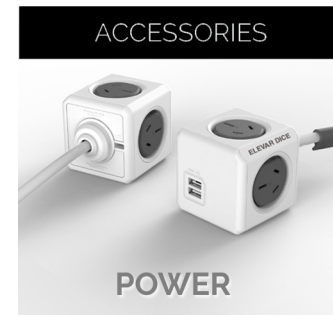
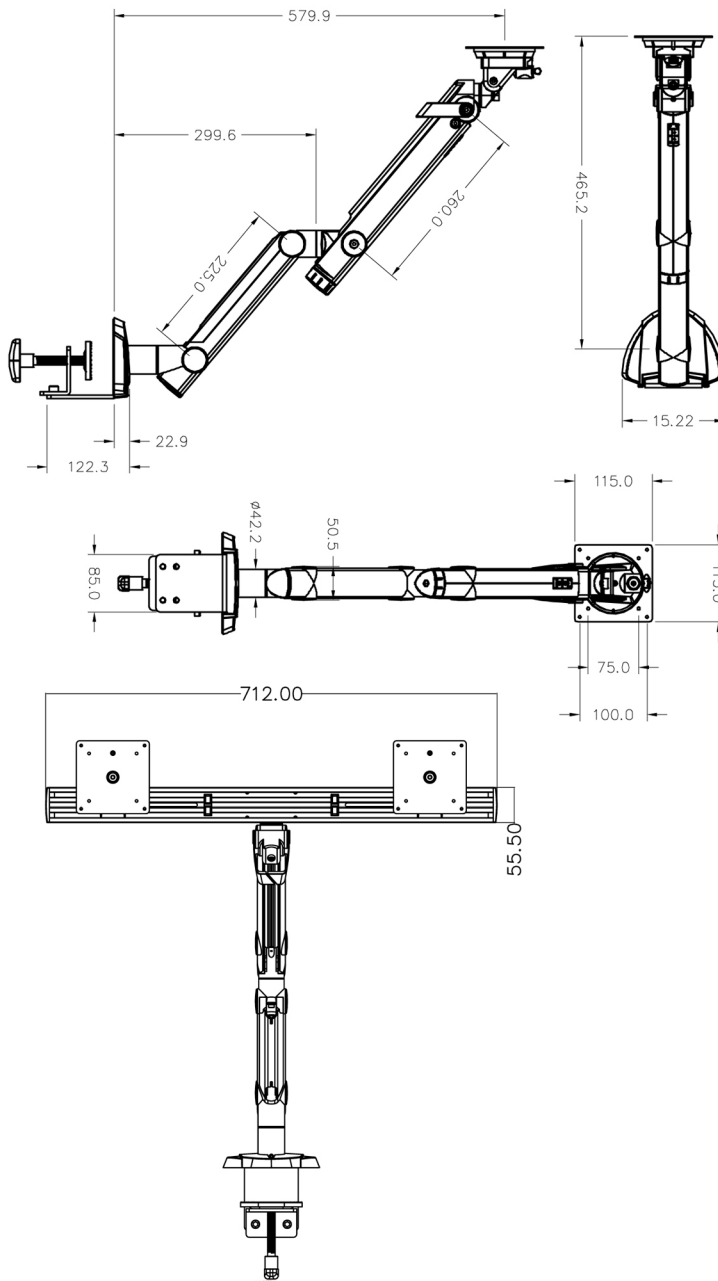

incorporate

www.incorporatespace.com.au